

Technical Specifications

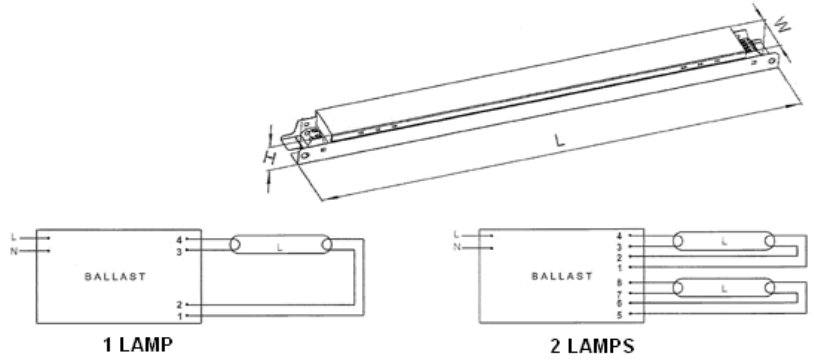

Electronic Ballasts for tubular T5 fluorescent lamps.
 Protection against open circuit and lamp failure.
 EEI=A2
 Voltage range: 220-240V

EN 61347-2-3, EN 61547, EN 55015,
 EN 61000-3-2, EN 60925, EN 60929
 Protection class I
 Preheat start

Type	BALLAST			ta / °C	tc / °C	λ	LAMP		
	Dimensions/ mm						Type	Power/W	Socket
	W	H	L						
2X14-35	30	30	30	-15 +50	70	0.98	T5	2X14 2X21 2X28 2X35	G5