

TECHNICAL SPECIFICATIONS PRE-MOUNTED KITS FOR HS AND HI LAMPS (230V/ 50Hz)

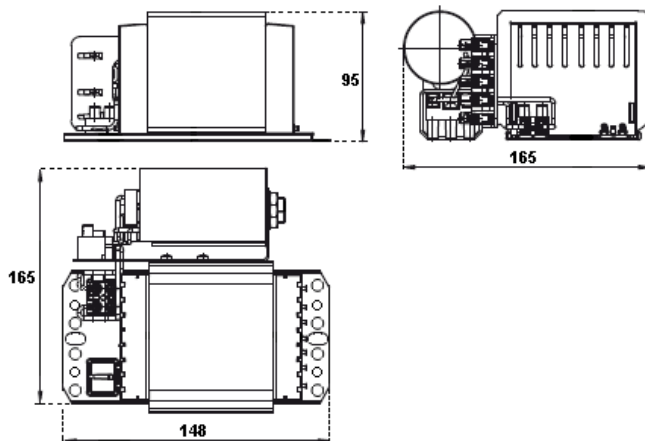

Pre-mounted kits for HS and HI Lamps
Includes ballast, ignitor, capacitor

Max length to the lamp : 1,5m
With earth terminal
Permissible load capacity : 20-100 pF
With automatic reset
No temperature protection

Ballast Shape : 92x102mm
Impregnated in polyester resin
Screw Terminal : 0,75 - 2,5 mm²
tw 130, Protection Class I

EN 61347:2008+A1:2011, EN 61347-2-9:2001+A1:2003+A2:2006 , EN 60923:2005+A1:2006
IEC 61347 (Safety)
IEC 62384 (Working Method)
ISO 9001/2008
EEI=A2



PRE-MOUNTED KITS FOR HS AND HI LAMPS (230V/ 50Hz)

Ballast Type	LAMP		Nominal current	Power factor λ	WEIGHT kg	TEMPERATURE tw	DIMENSIONS			CAPACITOR μ F
	TYPE	OUTPUT					L	W	H	
PKNAHJ 400-557.6	HI/HS	400W	4,45A	>0,90	5,7	130°C	148 mm	165 mm	95 mm	50